

CEDARAPIDS®
A TEREX BRAND

Portable Plants

CRJ3042
Jaw Plant

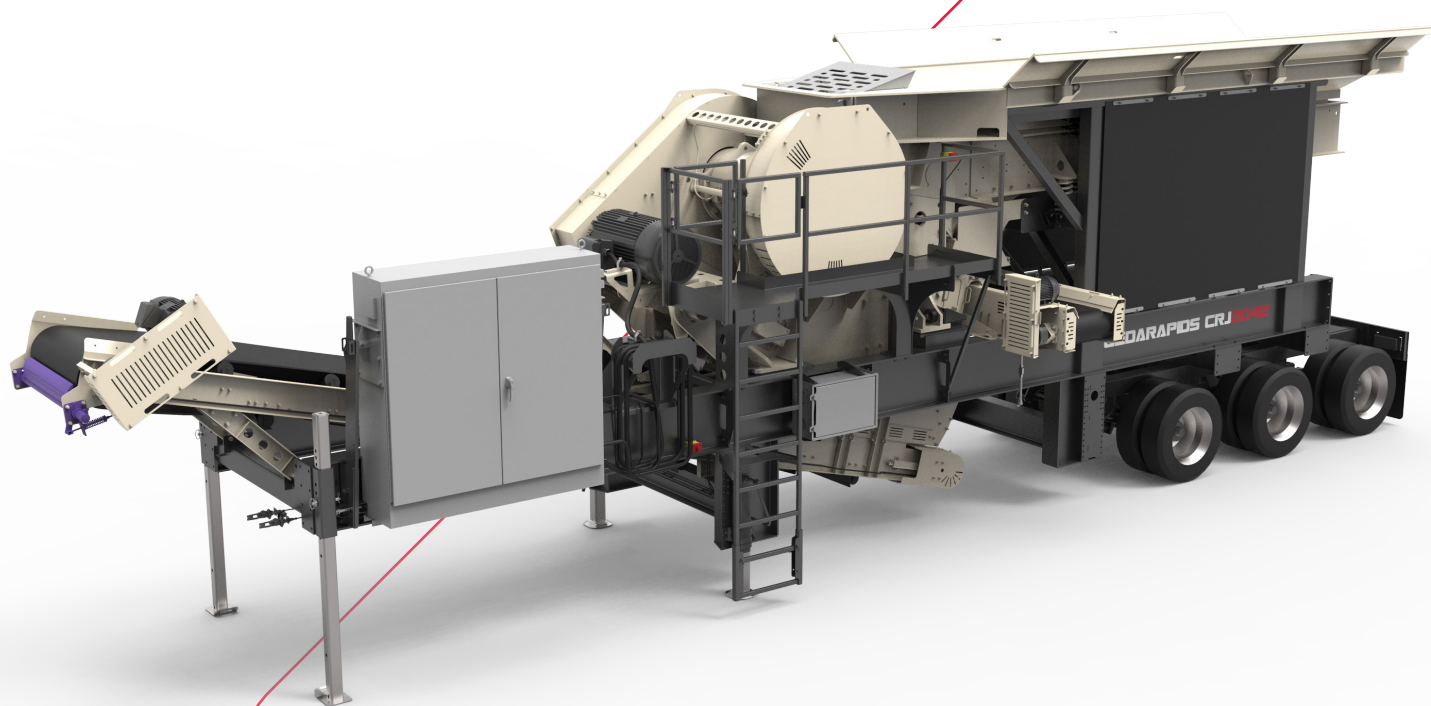

A world working better™

 **TEREX®** MPS

Cedarapids® Portable Plants

CRJ3042 Jaw Plant

The Cedarapids® CRJ3042 plant combines the popular JW42 jaw crusher with a high stroke, 42" x 20' (1067 x 6096 mm) vibrating grizzly feeder resulting in a high production portable crushing machine. This plant includes a hopper design that can handle severe primary crushing applications. The highly mobile CRJ3042 is easy to operate and maintain and offers new levels of reliability and convenience. The jaw crusher has features such as wedge release jaw faces and fully hydraulic wedge jaw crusher setting. Multiple options are available, allowing customers to configure the CRJ3042 to meet specific needs.

Standard Features

JW42 Jaw Crusher

- Hydraulic wedge jaw adjustment
- Hydraulic tension rod
- Electric/hydraulic adjust unit
- Quick change jaw die wedge system with side access to stationary die
- High strength frame with bolted and dowelled construction
- Three-piece side cheek plates

4220-15 Vibrating Grizzly Feeder

- Hopper with 3/4" (19 mm) AR 400 sides
- Adjustable action vibrator unit with pivot base motor mounting
- Heavy coil springs with removable spring brackets
- 60" (1524 mm) bolted bar grizzly, 4" (102 mm) nominal openings
- Bypass chute diverts grizzly fines to undercrusher conveyor
- Rubber side curtains

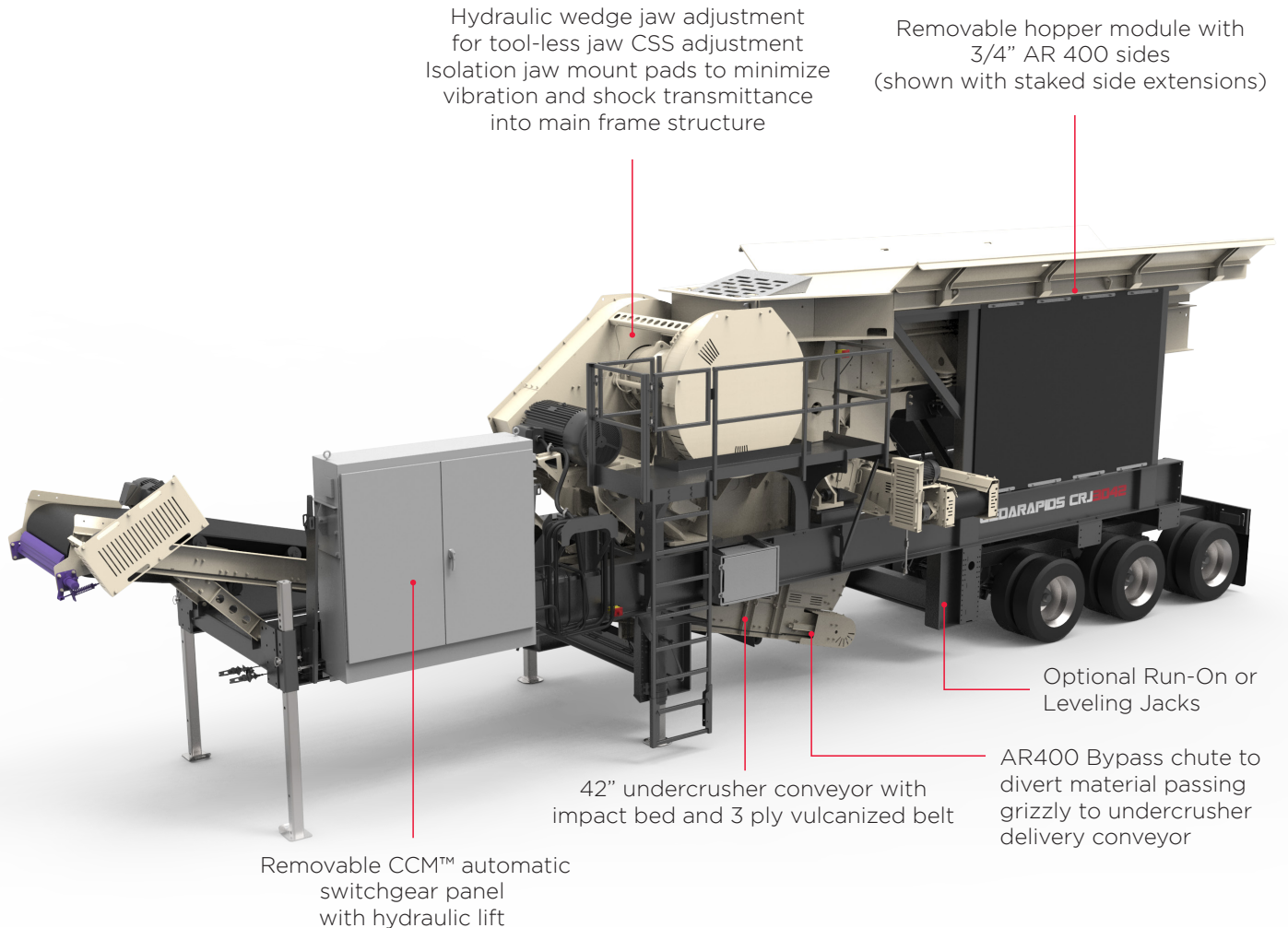

Undercrusher Conveyor

- Straight-line conveyor design
- Shaft mount gear box and TEFC motor
- Impact bars under jaw and grizzly bypass
- 3-ply conveyor belt with vulcanized splice
- Continuous supported hopper flashing on diverging hopper minimizes spillage and clean up

Main Frame with Triple Axle

- Straight beam chassis with kingpin, under-frame mounted axles, spring suspension, air brakes, travel lights and splash guards
- Jaw mount vibration isolation pads
- Emergency stops on both sides of chassis
- Twelve 295/75 R22.5 tires
- Adjustable kingpin support legs
- Service and observation platforms
- Remote grease lines
- Lockable side-mounted storage box

Specifications	Dimensions		Operating Speed
Jaw crusher	30" x 42"	760 mm x 1067 mm	250 rpm
Undercrusher conveyor	42"	1067 mm	300 rpm
Cross conveyor (optional)	24"	610 mm	

Feeder	42" x 20'	1067 mm x 6096 mm	variable 600 - 800 rpm
Bolted bar grizzly	60" x 4"	1524 mm x 102 mm	
AR pan liners	1/2"	12.7 mm	

Power Requirements	hp	kW
Jaw	150	110
Jaw hydraulic controls	3	2
Feeder	40	30
Undercrusher conveyor	15	11
Cross conveyor (optional)	5	3.7
Self-cleaning magnet (optional)	1.5	1
Dust suppression pump (optional)	0.75	0.5

Estimated Weights*	Axles	Kingpin	Total
Standard wheel base plant	58,235 lbs (26,415 kg)	43,535 lbs (19,750 kg)	101,770 lbs (46,165 kg)

*Weights include optional switchgear, jacks and hydraulics. Contact factory for weights of other optional equipment.

Transport

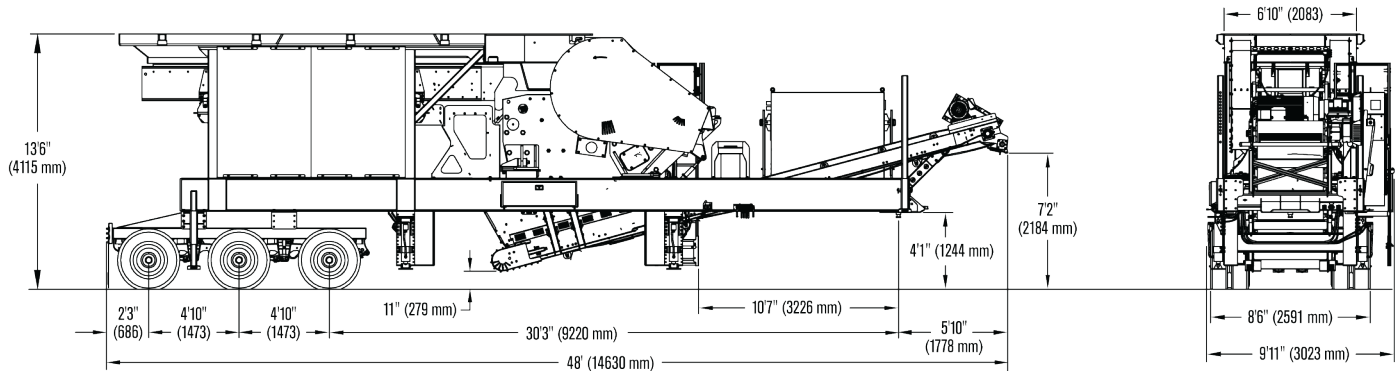

Operational

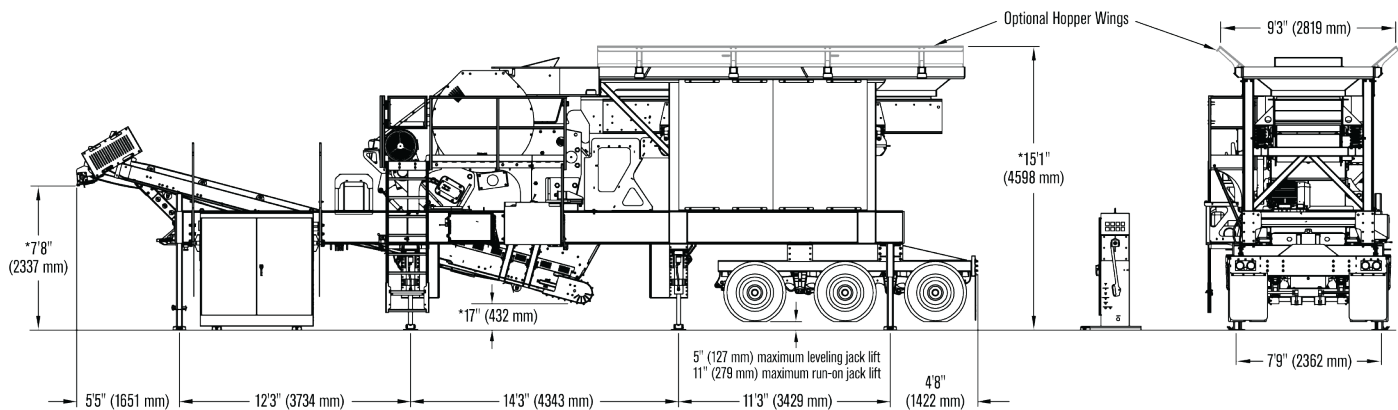

*Heights shown on 18" (457 mm) leveling jacks, 24" (610 mm) run-on jacks are also available.

Optional equipment

- Removable electrical switchgear panel, wiring and operator
- push-button station
- Hydraulic lift system for switchgear panel
- Tethered or wireless remote feeder control
- Staked 20" (508 mm) hopper wing extensions
- Grizzly reject cross conveyor
- Various grizzly bar spacing
- Bolt-in stepped tine grizzly in place of standard bars
- Dust suppression water spray system
- Cross belt self-cleaning magnet
- Hydraulic leveling or run-on jacks (gas, 12V, or 24V in hinged enclosure)
- Crank style landing jacks
- Oversize 315/80 R22.5 tires

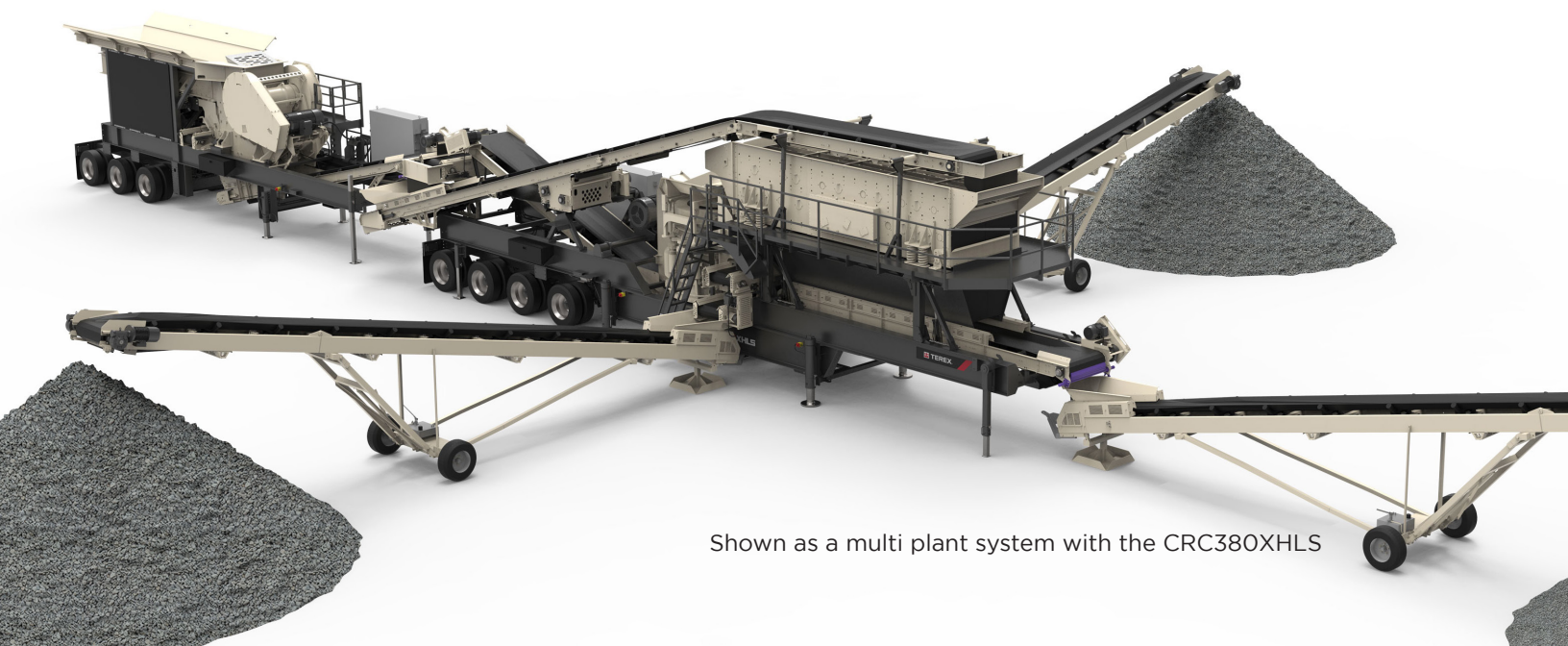

Shown as a multi plant system with the CRC380XHLS

North America

3900 Fountains Blvd NE, Suite 101
Cedar Rapids, IA 52411
Tel: +1 319 363 3511 or +1 800 821 5600
Fax: +1 319 399 4871

212 South Oak Street
Durand, MI 48429
Tel: +1 989 288 3121
Fax: +1 989 288 4113

www.terexmps.com
mpsmarketing@terex.com

Product specifications and prices are subject to change without notice or obligation. The photographs and/or drawings in this document are for illustrative purposes only. Refer to the appropriate Operator's Manual for instructions on the proper use of this equipment.

Failure to follow the appropriate Operator's Manual when using our equipment or failure to act responsibly may result in serious injury or death.

The only warranty applicable to our equipment is the standard written warranty applicable to the particular product and sale, and Terex makes no other warranty, express or implied. Terex, the Terex Crown design, Cedarapids, Canica, Simplicity, Jaques, El-Jay and Rollercone are trademarks of Terex Corporation or its subsidiaries. All rights are reserved. © June 2020