

GLADIATOR™

R A N G E

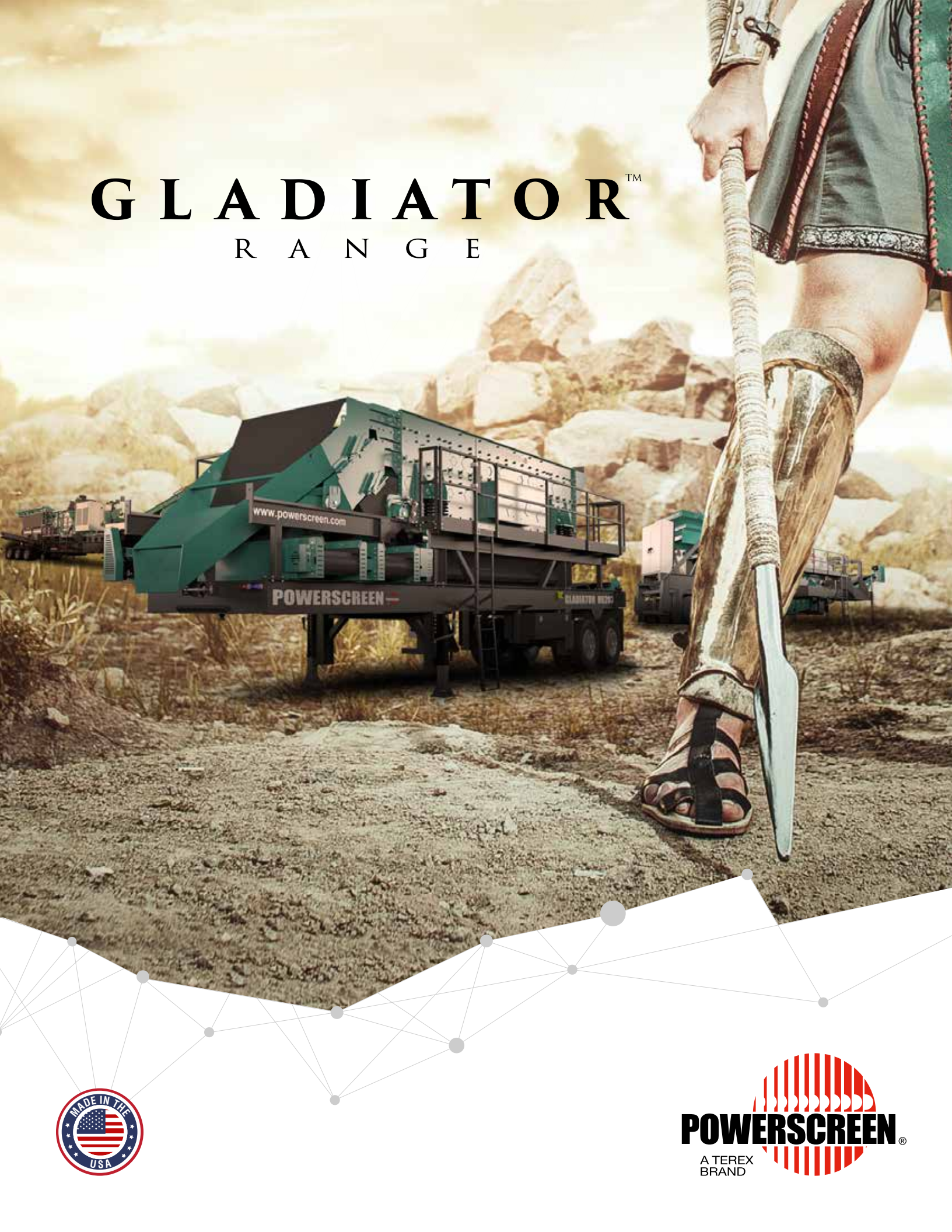



Simplicity of operation
Very easy to set-up & use with simple, reliable push button controls



Powerscreen Hybrid
Electrically driven with no costly engine aftertreatment



Robust & reliable
Industry proven crushing & screening technology



Modular units
All Gladiator Machines are designed for maximum versatility and to work in a number of different setups as easily as possible.



The Powerscreen® Gladiator™ range is a new range of wheeled crushing & screening plant that is reliable, easy to operate and move and environmentally friendly.

The Gladiator range combines the highly efficient crushing chambers and screenboxes that Powerscreen is famed for, with the simplicity and flexibility of wheeled equipment.

The range is fully electrically driven using tried and tested Powerscreen® Hybrid™ technology, making it an ideal choice in locations with strict environmental regulations.

THE GLADIATOR RANGE INCLUDES:



Gladiator PT400
Jaw Crusher



Gladiator TP320SR
Closed-circuit Impact Crusher



Gladiator MT1150
Open-circuit Cone Crusher



Gladiator MT1150SR
Closed-circuit Cone Crusher



Gladiator MT1300
Open Circuit Cone Crusher



Gladiator H6203
Horizontal Screen



Gladiator H8203
Horizontal Screen

GLADIATOR™ PT400



The Gladiator PT400 is a new electrically driven, wheeled jaw crusher. It features the tried-and-tested JW42 jaw crushing chamber and is chassis mounted on wheels meaning ease of movement and set-up.

The Gladiator PT400 is fully electrically driven using tried and tested Powerscreen® Hybrid™ technology, making it an ideal choice in locations with strict environmental regulations.



APPLICATIONS

AGGREGATE	RECYCLING	MINING
<ul style="list-style-type: none"> Sand & gravel Blasted rock River rock 	<ul style="list-style-type: none"> Top Soil C&D waste Composed materials Wood By-Products Overburden Foundry Waste 	<ul style="list-style-type: none"> Processed ores Processed minerals

TECHNICAL HIGHLIGHTS



RELIABLE & EASY TO OPERATE

- Simple, reliable push button controls
- Vibrating grizzly feeder removes fines before crushing
- Aggressive crushing action by renowned JW42 jaw chamber
- Hydraulic adjustments at ground level

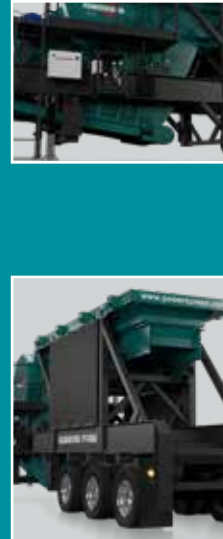

ROAD-LEGAL & EASY TO MOVE

- Made locally in USA, with lowest possible weight for ease of movement
- Triple axle chassis with 12 wheels, spring suspension and air brakes as standard



ENVIRONMENTALLY FRIENDLY

- Electrically driven by either external genset or 3 phase mains connection
- No costly engine aftertreatment reducing expensive engine maintenance costs



TECHNICAL SPECIFICATION

1 FEEDER Vibrating grizzly feeder Length: 20' (6096 mm) Width: 42" (1067mm) Bolted bar grizzly Length: 60" (1524 mm) x 4" (102 mm) average opening	4 CHASSIS & TIRES Straight beam chassis Spring suspension & air brakes Kingpin, under-frame mounted triple axle Tires: 12 x 295/75 R22.5												
2 CRUSHER Feed Opening: 42" x 30" (1070mm x 760mm) Operating Speed: 250rpm Power: 150hp (110 kW)	5 POWER UNIT Electrically Driven External Power Requirements 460V (575V Option if required) 3 Phase 60 Hz												
3 DISCHARGE CONVEYOR AND UNDERCRUSHER CONVEYOR Width: 42" (1070mm) Discharge Height: 9' 2" (2.8m) Manufactured from 1/4" (6mm) mild steel Rock ledge with AR400 3/8" (10mm) liners Rubber flashing Access on both sides to allow easy setting of CSS	POWER <table border="1"> <tbody> <tr> <td>Jaw</td> <td>150hp (112kW)</td> </tr> <tr> <td>Discharge Conveyor</td> <td>15hp (11kW)</td> </tr> <tr> <td>VGf</td> <td>40hp (30kW)</td> </tr> <tr> <td>Optional Bypass Conveyor</td> <td>7.5hp (5.6kW)</td> </tr> <tr> <td>Optional Magnet</td> <td>2hp (1.5kW)</td> </tr> <tr> <td>Total Power Required</td> <td>214.5hp (160kW)</td> </tr> </tbody> </table>	Jaw	150hp (112kW)	Discharge Conveyor	15hp (11kW)	VGf	40hp (30kW)	Optional Bypass Conveyor	7.5hp (5.6kW)	Optional Magnet	2hp (1.5kW)	Total Power Required	214.5hp (160kW)
Jaw	150hp (112kW)												
Discharge Conveyor	15hp (11kW)												
VGf	40hp (30kW)												
Optional Bypass Conveyor	7.5hp (5.6kW)												
Optional Magnet	2hp (1.5kW)												
Total Power Required	214.5hp (160kW)												

DIMENSIONS



WEIGHT

Total Weight: 107,200lbs (48,625kg)
Axle Load: 64,000lbs (29,030kg)
King Pin Load: 43,200lbs (19,595kg) +5,600 (2,540kg) for magnet & stand

*Please note: It is the dealer's responsibility to ensure the plant is road legal in their region and the guards comply to the customers requirements.

GLADIATOR™ TP320SR



The Gladiator TP320SR is a new hybrid-electric drive, wheeled, closed-circuit impact crusher.

This portable closed circuit crushing and screening plant combines the tried and tested Trakpactor 320 impact crusher and Chieftain 1700 2 deck inclined screenbox for recirculation.

The crusher is hydraulic clutch driven direct from a 350hp Scania diesel engine. All other components are electrically driven from the 150kw generator.

The Gladiator TP320SR, with its large screenbox, wide conveyors and low maintenance electric drive components, promises to be a highly productive, high value plant.



APPLICATIONS

AGGREGATE



Sand & gravel
Blasted rock
River rock

RECYCLING



Top Soil
C&D Waste
Composed materials
Wood By-Products
Overburden
Foundry Waste

MINING



Processed ores
Processed minerals

TECHNICAL HIGHLIGHTS



HIGH RELIABILITY, HIGH OUTPUT

- High performance impact chamber combined with the iconic Chieftain 1700 2-deck screenbox giving reliable crushing and screening with one plant
- Vibrating grizzly feeder removes fines before crushing
- Aggressive crushing action by renowned Trakpactor 320 impact chamber
- Simple, reliable push button controls with additional starters as standard



ROAD-LEGAL & EASY TO MOVE

- Made locally in USA, with lowest possible weight for ease of movement
- Triple axle chassis with 12 wheels, spring suspension and air brakes ensuring a smooth journey



ENVIRONMENTALLY FRIENDLY

- Largely electrically driven by the onboard 150 kW generator
- Economical to operate
- Fully electric plant available

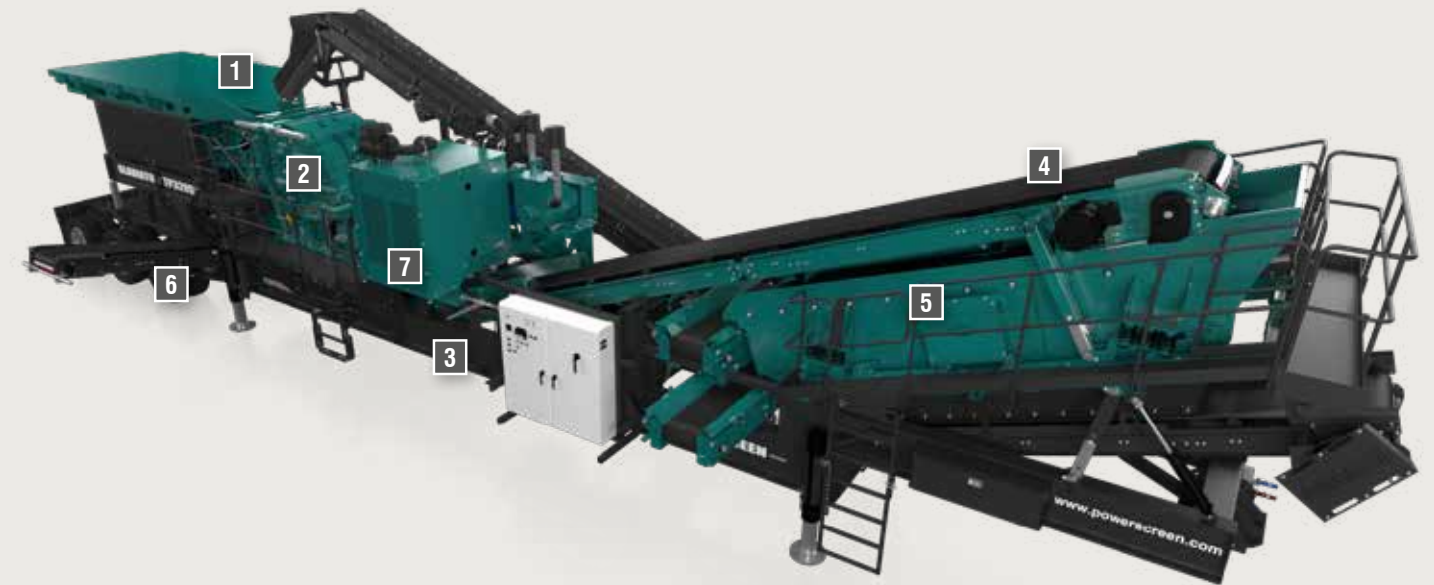

TECHNICAL SPECIFICATION

1 FEEDER

Vibrating grizzly feeder
Length: 14' 3" (4.34m)
Width: 3' 6" (1.07m)
7" Stepped 2 deck grizzly
Length: 84" (2135mm)

2 CRUSHER

Feed opening: 44.5" x 31.5"
(1130mm x 800mm)
Operating Speed: TBC rpm
Power: TBC hp (TBC kW)

3 BYPASS CHUTE AND UNDERCRUSHER CONVEYOR

Width: 42" (1070mm)
Automatic hydraulic tail lift for transport

4 FINES CONVEYOR

Width: 42" (1070mm)
Discharge Height: 8' 7" (2.6m)

5 SCREENBOX

16' x 5' (4.8m x 1.5m) 2 deck incline screen
Speed: 1050rpm
Highly aggressive screen drive

6 CHASSIS & TIRES

Spring suspension & air brakes
Kingpin, under-frame mounted triple axle
Tires: 12 x 295/75 R22.5

7 POWER UNIT

Tier 4F: Scania 350hp
Onboard Genset: 150kW
460V
3 Phase
60Hz
Option for Tier 3 engine

DIMENSIONS

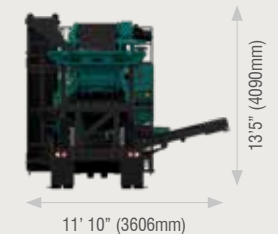

WEIGHT

	Kingpin Weights	Axle Weights
Base Plant	39,958lbs (18,125kg)	54,048lbs (24,516kg)
+ Dirt Conveyor	467lbs (212kg)	2,128lbs (965kg)

*Please note: It is the dealer's responsibility to ensure the plant is road legal in their region and the guards comply to the customers requirements.

GLADIATOR™ MT1150



The Gladiator MT1150 is a new electrically driven, wheeled open circuit cone crusher. It features the renowned Terex (r) TC1150 cone chamber and is chassis mounted on wheels meaning ease of movement and quick set up times.

The Gladiator MT1150 is fully electrically driven using renowned Powerscreen Hybrid technology, which makes it an ideal solution in areas where strict environmental regulations are in place.



APPLICATIONS

AGGREGATE



Sand & gravel
Blasted rock
River rock

RECYCLING



Top Soil
C&D Waste
Composed materials
Wood by-products
Overburden
Foundry Waste

MINING



Processed ores
Processed minerals

TECHNICAL HIGHLIGHTS



AGGRESSIVE CRUSHING PERFORMANCE

- Renowned Terex® TC1150 cone chamber gives high productivity and excellent product shaping
- 300 hp (225 kW), 1800 rpm crusher motor and drive are mounted with the crusher on a rubber isolated frame
- Crusher controlled by the Terex ACE6, allowing the operator to achieve maximum performance from their crusher, but also improve their crushing plant's reliability & uptime.



EXCELLENT MAINTENANCE ACCESS

- Conveniently located grease banks and ground access cone lubrication module
- Service platforms around crusher, elevated observation platform
- Side-mounted lockable box for convenient tool storage



ROAD-LEGAL & EASY TO MOVE

- Made locally in USA, with lowest possible weight for ease of movement
- Tandem axle chassis with 8 wheels and spring suspension ensuring a smooth journey



ENVIRONMENTALLY FRIENDLY

- Electrically driven with onboard generator
- No costly engine aftertreatment reducing expensive engine maintenance costs



TECHNICAL SPECIFICATION

1 HOPPER

Oversize quick-release cone feed hopper with gated overflow chute
Manufactured from 1/4" (6mm) mild steel

2 CRUSHER

Maximum feed size – medium coarse 7.5" (190 mm)
Power: 300hp (225 kW)
Standard Mantle & Medium Coarse Concave
Short throw chamber as standard, long throw chamber available as an option.

3 UNDERCRUSHER CONVEYOR

Width: 42" (1067 mm)
Length: 34' 6" (10515mm)
Motor: 15hp (11 kW) electric motor
Discharge Height: TBC

4 CHASSIS & TIRES

Heavy Duty 25,000lb Leaf Spring Suspension
(8) 11R x 22.5 tires

5 POWER UNITS

Electrically driven

POWER

Cone	300hp (224kW)
Discharge Conveyor	15hp (11kW)
Optional Metal Detector	2hp (1.5kW)
Total Power Required	317hp (236.5kW)

DIMENSIONS

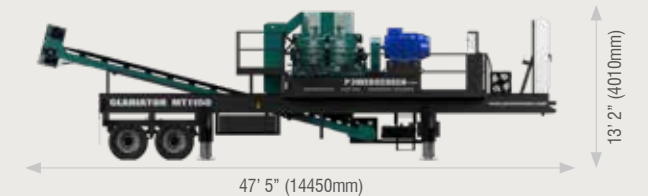

47' 5" (14450mm)

13' 2" (4010mm)



11' 11" (3630mm)

13' 2" (4010mm)

WEIGHT

Total Weight: 68,530lbs (31,085kg)
Axle Load: 38,000lbs (17,237kg)
King Pin Load: 30,700lbs (13,925kg)

Short throw chamber as standard, long throw chamber available as an option.

*Please note: It is the dealer's responsibility to ensure the plant is road legal in their region and the guards comply to the customers requirements.

GLADIATOR™ MT1150SR



The Powerscreen Gladiator MT1150SR is a wheeled, electric drive closed circuit cone crushing /screening plant.

This closed circuit crushing and screening plant incorporates the tried and tested TC1150 cone crushing chamber coupled with the 20' x 6' H6203 Horizontal screenbox for recirculation while being chassis mounted on wheels means ease of movement and quick set up times.

The Gladiator MT1150SR is fully electrically driven using renowned Powerscreen Hybrid technology, which makes it an ideal solution in areas where strict environmental regulations are in place.



APPLICATIONS

AGGREGATE	RECYCLING	MINING
<ul style="list-style-type: none"> Sand & gravel Blasted rock River rock 	<ul style="list-style-type: none"> Top Soil C&D Waste Composed materials Wood by-products Overburden Foundry Waste 	<ul style="list-style-type: none"> Processed ores Processed minerals

TECHNICAL HIGHLIGHTS



AGGRESSIVE CRUSHING PERFORMANCE

- Renowned Terex® TC1150 cone chamber gives high productivity and excellent product shaping
- 300 hp (225 kW), 1800 rpm crusher motor and drive are mounted with the crusher on a rubber isolated frame
- Crusher controlled by the Terex ACE6, allowing the operator to achieve maximum performance from their crusher, but also improve their crushing plant's reliability & uptime.



EXCELLENT MAINTENANCE ACCESS

- Conveniently located grease banks and ground access cone lubrication module
- Service platforms around crusher, elevated observation platform
- Side-mounted lockable box for convenient tool storage



ROAD-LEGAL & EASY TO MOVE

- Made locally in USA, with lowest possible weight for ease of movement
- Tandem axle chassis with 8 wheels and spring suspension ensuring a smooth journey

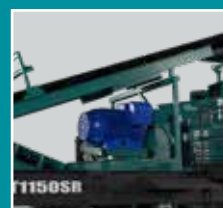

ENVIRONMENTALLY FRIENDLY

- Electrically driven with onboard generator
- No costly engine aftertreatment reducing expensive engine maintenance costs

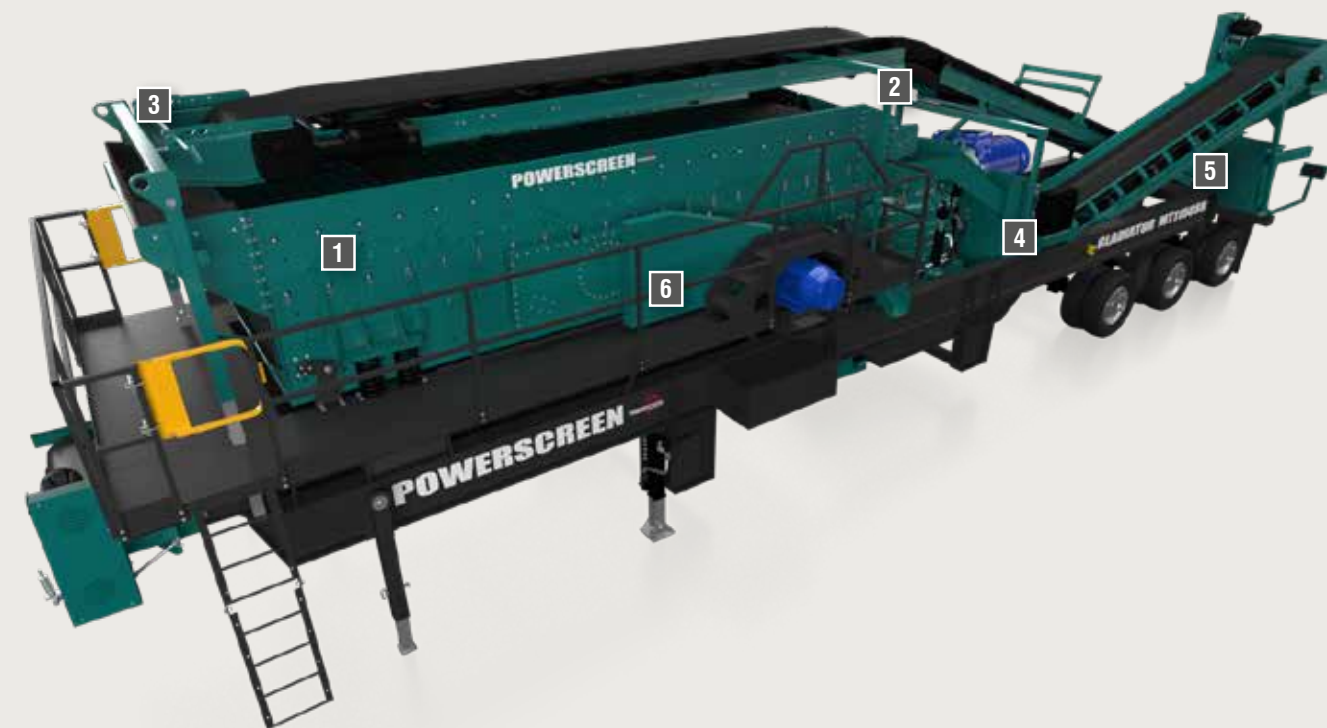

TECHNICAL SPECIFICATION

1 SCREENBOX	5 CHASSIS & TIRES																
3 deck triple shaft horizontal screenbox 6.1m x 1.93m (20' x 6' 4") (all decks) Oval stroke adjustable up to maximum of 19mm	Triple trunnion axle - sprung suspension (24) 11R x 22.5 tires Spring applied air brakes																
2 CRUSHER	6 POWER UNITS																
Maximum feed size - medium coarse 7.5" (190 mm) Power: 300hp (225 kW) Standard Mantle & Medium Coarse Concave Short throw chamber as standard, long throw chamber available as an option.	Electrically driven																
3 DISCHARGE CONVEYOR	⚡ POWER																
Belt Width: 54" (1370mm) Discharge Height: 4' 5" (1.35m) Motor: 10hp (7.5kW)	<table border="1"> <tbody> <tr> <td>Cone</td> <td>300hp (224kW)</td> </tr> <tr> <td>Screenbox</td> <td>40hp (30kW)</td> </tr> <tr> <td>Discharge Conveyor</td> <td>10hp 7.5kW</td> </tr> <tr> <td>Over Screen Conveyor</td> <td>20hp 15kW</td> </tr> <tr> <td>Under Screen Conveyor</td> <td>10hp 7.5kW</td> </tr> <tr> <td>Cross Conveyor</td> <td>5hp 3.7kW</td> </tr> <tr> <td>Optional Magnet</td> <td>2hp 1.5kW</td> </tr> <tr> <td>Total Power Required</td> <td>387hp (290kW)</td> </tr> </tbody> </table>	Cone	300hp (224kW)	Screenbox	40hp (30kW)	Discharge Conveyor	10hp 7.5kW	Over Screen Conveyor	20hp 15kW	Under Screen Conveyor	10hp 7.5kW	Cross Conveyor	5hp 3.7kW	Optional Magnet	2hp 1.5kW	Total Power Required	387hp (290kW)
Cone	300hp (224kW)																
Screenbox	40hp (30kW)																
Discharge Conveyor	10hp 7.5kW																
Over Screen Conveyor	20hp 15kW																
Under Screen Conveyor	10hp 7.5kW																
Cross Conveyor	5hp 3.7kW																
Optional Magnet	2hp 1.5kW																
Total Power Required	387hp (290kW)																
4 UNDERCRUSHER CONVEYOR																	
Width: 36" (915mm) Motor: 10hp (7.5kW) WEG Conveyor is fully skirted																	

DIMENSIONS

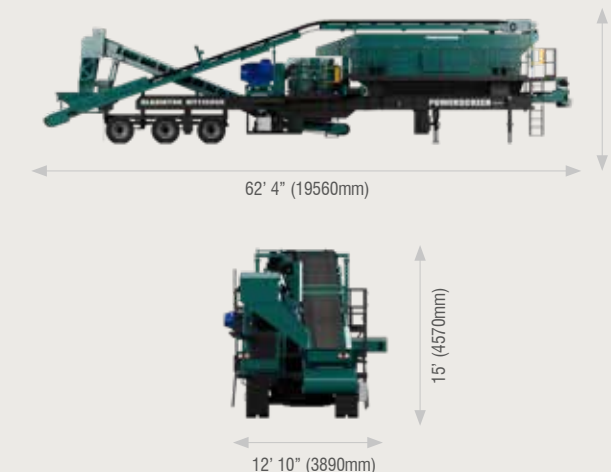

WEIGHT

Total Weight: 115,000 lbs (52,163kg)
Axle Load: 64,500lbs (29,257kg)
King Pin Load: 55,000 lbs (24,938 kg)

Short throw chamber as standard, long throw chamber available as an option.

*Please note: It is the dealer's responsibility to ensure the plant is road legal in their region and the guards comply to the customers requirements.

GLADIATOR™ MT1300



The new Gladiator MT1300 is an electrically driven, wheeled open circuit cone crusher. It features the tried and tested Terex TC1300 cone chamber and is mounted on wheels which ensures ease of movement and quick set up times.

The Gladiator MT1300 is fully electrically driven and can be powered from an external source or onboard via generator, which makes it an ideal solution in areas where strict environmental regulations are in place.



APPLICATIONS

AGGREGATE



Sand & gravel
Blasted rock
River rock

RECYCLING



Top Soil
C&D Waste
Composed materials
Wood by-products
Overburden
Foundry Waste

MINING



Processed ores
Processed minerals

TECHNICAL HIGHLIGHTS



AGGRESSIVE CRUSHING PERFORMANCE

- Renowned Terex® TC1300 cone chamber gives high productivity and excellent product shaping
- 300 hp (225 kW), 1800 rpm crusher motor and drive are mounted with the crusher on a rubber isolated frame
- Crusher controlled by the Terex ACE6, allowing the operator to achieve maximum performance from their crusher, but also improve their crushing plant's reliability & uptime.



EXCELLENT MAINTENANCE ACCESS

- Conveniently located grease banks and ground access cone lubrication module
- Service platforms around crusher, elevated observation platform
- Side-mounted lockable box for convenient tool storage



ROAD-LEGAL & EASY TO MOVE

- Made locally in USA, with lowest possible weight for ease of movement
- Heavy Duty Tandem walking beam suspension, triple sprung axle and 12 wheels ensures a smooth journey



ENVIRONMENTALLY FRIENDLY

- Electrically driven with onboard generator
- No costly engine aftertreatment reducing expensive engine maintenance costs



TECHNICAL SPECIFICATION

1 HOPPER

Bolt on adjustable overflow gate which discharges to under crusher conveyor
Hopper shape allows optimum crusher feed from multiple angles
Manufactured from 1/4" (6mm) mild steel

2 CRUSHER

Maximum Feed Size - Medium Coarse 8.5" (220mm)
Power: 300hp (225 kW)
Manganese Steel alloy mantle & concave
Standard Concave : Medium Coarse (MC)
(Optional 350hp motor)

3 UNDERCRUSHER CONVEYOR

Width: 42" (1067mm)
Motor: 15hp (11 kW) electric

4 CHASSIS & TIRES

Heavy Duty 25,000 Leaf Spring Suspension
(12) 11R x 22.5 tires

5 POWER UNITS

Electrically driven

POWER	
Cone	300hp (224 kW)
Discharge Conveyor	15hp (11 kW)
Optional Metal Detector	2 hp (1.5 kW)
Total Power Required	317 hp (236.5 kW)

DIMENSIONS



WEIGHT

Total Weight: 86,000lbs (39,009kg)
Axle Load: 52,500lbs (23,814kg)
King Pin Load: 33,500lbs (15,195kg)

*Please note: It is the dealer's responsibility to ensure the plant is road legal in their region and the guards comply to the customers requirements.

GLADIATOR™ H6203



The Gladiator H6203 is a new, electrically driven, wheeled horizontal screening plant which offers excellent screening and blending capabilities

It features the renowned Terex Cedarapids 20' x 6' heavy duty, triple shaft oval stroke screenbox which is chassis mounted on wheels meaning ease of movement and quick set up.

The Gladiator H6203 is a rugged and heavy-duty screening system, with many patented and patent-pending features. The unit is fully electrically driven using tried and tested Powerscreen® Hybrid™ technology, making it an ideal choice in locations with strict environmental regulations.



APPLICATIONS

AGGREGATE



Sand & gravel
Blasted rock
River rock

RECYCLING



Top Soil
C&D Waste
Composed materials
Wood By-Products
Overburden
Foundry Waste

MINING



Processed ores
Processed minerals

TECHNICAL HIGHLIGHTS

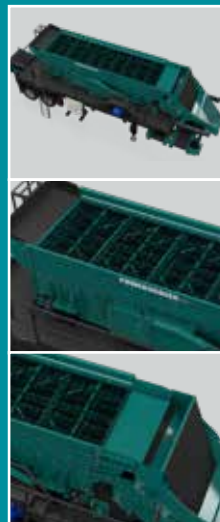

PATENTED OPERATION & MAINTENANCE FEATURES

- Patented triple-shaft lubrication system
- Patent-pending low maintenance surge dampers/ship braces
- Heavy-duty roll-away blending chutes for screen mesh access and serviceability. Also fitted with Four section (25%) blending gates for all decks to allow combination of products on all decks.
- Motor Step over and extended walkway on the right hand side as standard



ROAD-LEGAL & EASY TO MOVE

- Made locally in USA, with lowest possible weight for ease of movement
- 8 wheel sprung axle and air brakes ensure a smooth journey



ENVIRONMENTALLY FRIENDLY

- Electrically driven meaning low fuel emissions and running cost
- No costly engine aftertreatment reducing expensive engine maintenance costs

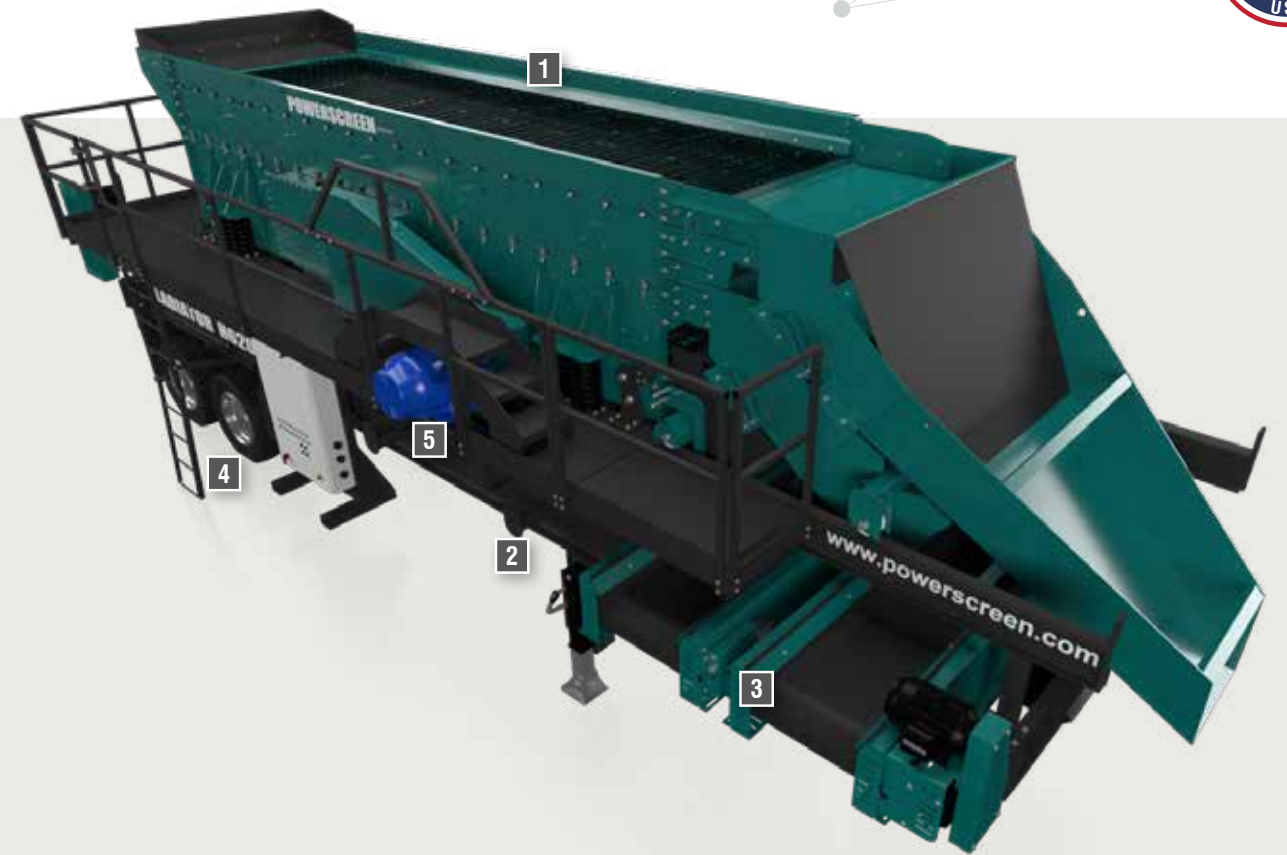

TECHNICAL SPECIFICATION

1 SCREENBOX
3 deck triple shaft horizontal screenbox
Length: 20' (6100mm)
Width: 6' 4" (1930mm)
Proven triple shaft technology
Adjustable stroke length & angle

2 UNDERSCREEN CONVEYOR
Width: 48" (1220mm)
Motor: 7.5hp (5.6kW)
Discharge Height: 5' 4" (1.63m)

3 CROSS CONVEYORS
Width: 30" (760mm)
Motor: 7.5hp (5.6kW)
Discharge Height: 6' (1830mm)
Reversible as standard with Switchgear

4 CHASSIS & TIRES
Heavy duty tandem walking beam suspension
Air brakes
Tires: 8 x 295/75 R22.5
Landing Jacks: Two Crank-Style

5 POWER UNIT
Electrically driven

POWER

Screenbox	40hp (30kW)
Underscreen Conveyor	7.5hp (5.6kW)
Cross Conveyor x 2	7.5hp (5.6kW)x2
Total Power Required	62.5hp (47kW)

DIMENSIONS



WEIGHT

Total Weight: 54,250kg (24,607kg)
Axle Load: 30,500lbs (13,834kg)
King Pin Load: 23,750lbs (10,772 kg)

*Please note: It is the dealer's responsibility to ensure the plant is road legal in their region and the guards comply to the customers requirements.

GLADIATOR™ H8203



The Gladiator H8203 is a new, electrically driven, wheeled horizontal screening plant which offers excellent screening and blending capabilities

It features the renowned Terex Cedarapids 20' x 8' heavy duty, triple shaft oval stroke screenbox which is chassis mounted on wheels meaning ease of movement and quick set up.

The Gladiator H8203 is a rugged and heavy-duty screening system, with many patented and patent-pending features. The unit is fully electrically driven using tried and tested Powerscreen® Hybrid™ technology, making it an ideal choice in locations with strict environmental regulations.



APPLICATIONS

AGGREGATE	RECYCLING	MINING
<ul style="list-style-type: none"> Sand & gravel Blasted rock River rock 	<ul style="list-style-type: none"> Top Soil C&D Waste Composed materials Wood By-Products Overburden Foundry Waste 	<ul style="list-style-type: none"> Processed ores Processed minerals

TECHNICAL HIGHLIGHTS



PATENTED OPERATION & MAINTENANCE FEATURES

- Patent-pending low maintenance surge dampers/ship braces
- Heavy-duty roll-away blending chutes for screen mesh access and serviceability. Also fitted with Four section (25%) blending gates for all decks to allow combination of products on all decks.
- Extended Walkway on Left hand side of the machine to allow easy mesh changes

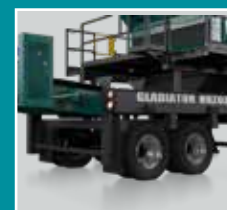

ROAD-LEGAL & EASY TO MOVE

- Made locally in USA, with lowest possible weight for ease of movement
- 8 wheel sprung axle and air brakes ensure a smooth journey



ENVIRONMENTALLY FRIENDLY

- Electrically driven meaning low fuel emissions and running cost
- No costly engine aftertreatment reducing expensive engine maintenance costs



TECHNICAL SPECIFICATION

1 SCREENBOX 3 deck triple shaft horizontal screenbox Length: 20' (6100mm) Width: 8' 4" (2540mm) Proven triple shaft technology Adjustable stroke length & angle	4 CHASSIS & TIRES Heavy duty tandem Leaf Spring suspension Landing Jacks: Two Crank-Style Air brakes Tires: 8 x 11R x 22.5								
2 UNDERSCREEN CONVEYOR Width: 60" (1520mm) Motor: 10hp (7.5kW) Discharge Height: 5' 4" (1.63m)	5 POWER UNIT Electrically driven								
3 CROSS CONVEYORS Width: 36" (900mm) Motor: 7.5hp (5.6kW) Discharge Height: 6' (1830mm) Reversible as standard with Switchgear	POWER <table border="1"> <tbody> <tr> <td>Screenbox 50hp (37kw)</td> <td>40hp (30kW)</td> </tr> <tr> <td>Underscreen Conveyor 10hp (7.5kW)</td> <td>7.5hp (5.6kW)</td> </tr> <tr> <td>Cross Conveyor x 2 7.5hp (5.6kW)x2</td> <td>7.5hp (5.6kW)x2</td> </tr> <tr> <td>Total Power Required</td> <td>75hp (55.7kW)</td> </tr> </tbody> </table>	Screenbox 50hp (37kw)	40hp (30kW)	Underscreen Conveyor 10hp (7.5kW)	7.5hp (5.6kW)	Cross Conveyor x 2 7.5hp (5.6kW)x2	7.5hp (5.6kW)x2	Total Power Required	75hp (55.7kW)
Screenbox 50hp (37kw)	40hp (30kW)								
Underscreen Conveyor 10hp (7.5kW)	7.5hp (5.6kW)								
Cross Conveyor x 2 7.5hp (5.6kW)x2	7.5hp (5.6kW)x2								
Total Power Required	75hp (55.7kW)								

DIMENSIONS

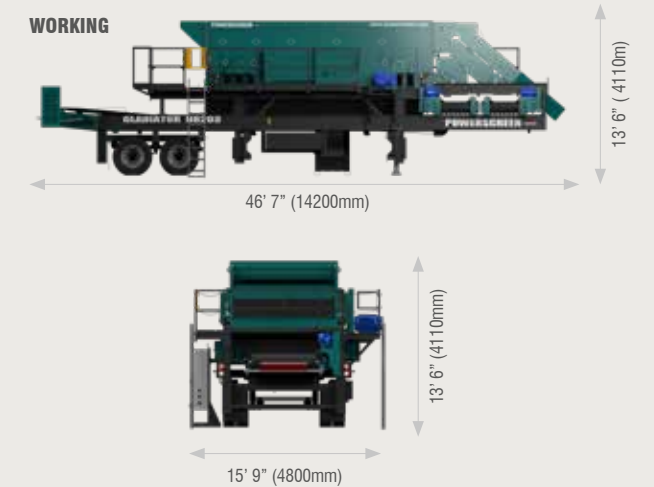

TRANSPORT
 Length: 43' 4" (13.21m)
 Width: 11' 12" (3.66m)
 Height: 13' 6" (4.11m)

WEIGHT
 Total Weight: 65,500lbs (29,710kg)
 Axle Load: 37,000lbs (16,785kg)
 King Pin Load: 28,500lbs (12,925kg)

*Please note: It is the dealer's responsibility to ensure the plant is road legal in their region and the guards comply to the customers requirements.

GLADIATOR™

R A N G E



POWERSCREEN CONTACT DETAILS

Dungannon

200 Coalisland Road, Dungannon,
Co Tyrone, BT71 4DR, Northern Ireland
Tel: +44 (0) 28 87 718 500
Fax: +44 (0) 28 87 747 231

Louisville

11001 Electron Drive,
Louisville, Kentucky, 40299 USA
Tel: +1 502 736 5200
Fax: +1 502 736 5202

www.powerscreen.com

Email: mail@powerscreen.com

CONNECT WITH US

 @powerscreenofficial

 @powerscreen

 @powerscreenofficial

 @powerscreen

 @powerscreenofficial

The material in this document is for information only and is subject to change without notice.

Powerscreen assumes no liability resulting from errors or omissions in this document, or from the use of the information contained herein. Due to continual product development we reserve the right to change specifications without notice. Product performance figures given in this brochure are for guidance purposes only, this information does not constitute an expressed or implied warranty or guarantee. Results will vary depending on conveyor settings, feed source and types of material being processed. Will vary depending on crusher chamber settings, screen media and sizes, feed source and types of material being processed.

Images are for illustrative purposes only, some or all of the machines in the illustrations may be fitted with optional extras. Please check with your Dealer for details on optional extras.

Powerscreen® is a registered trademark of Terex GB Limited in the United States of America and many other countries. Copyright 2021 Terex GB Limited. Published and Printed in August 2021.

